

RalliTronic Power Pack

- | | | |
|-------------------------------------|------------------------------------|-------------------------------------|
| GB Fitting instructions | CZ Montážní pokyny | IT Istruzioni di montaggio |
| BG Инструкции за монтаж | GR Οδηγίες Τοποθέτησης | NL Inbouwhandleiding |
| DE Montageanleitung | EE Paigaldusjuhend | PT Instruções de montagem |
| ES Instrucciones de montaje | IS Ísetningar leiðbeiningar | SI Navodila za vgradnjo |
| FR Instructions de montage | PL Instrukcja montażu | LT Montavimo instrukcijos |
| HU Beszerelési útmutató | TR Montaj talimatı | LV Uzstādīšanas instrukcija |
| NO Monteringsveiledning | DK Monteringsvejledning | MK Инструкции за инсталирање |
| RO Instructiuni de instalare | FI Asennusohjeet | RS Uputstvo za instalaciju |
| SE Monteringsanvisning | HR Upute za instaliranje | |

Partnumber: MME41325 / MME41339MT			
Application			
Model name	Model year	Body	Model series
Pajero MT	2007 - 2008	LWB / SWB	V88 / V98

GB Read these instructions carefully before starting the installation. Due to the nature of this product, it is highly recommended that it is installed by a Mitsubishi Authorized Service Point. Modifications related to design, construction, illustrations and text are reserved.

BG Прочетете внимателно тези инструкции преди да започнете монтажа. Поради спецификата на този продукт е силно препоръчително той да бъде монтиран в Оторизиран Сервиз на Мицубиши. Всички промени по отношение на дизайн, конструкция, илюстрации и текст, са запазени.

DE Bitte lesen Sie die Montageanleitung ausführlich und beachten Sie die vorgegebenen Arbeitsschritte und Anweisungen. Aufgrund der technischen Komplexität, empfehlen wir Ihnen die Montage ausschließlich von einem autorisierten Mitsubishi-Vertragspartner durchführen zu lassen. Mitsubishi Motors behält sich Änderungen des Liefergegenstandes gegenüber den Angaben und Abbildungen in dieser Dokumentation, z.B. im Hinblick auf technische Daten, Konstruktion und äußeres Erscheinungsbild, vor.

ES Lea por tanto con atención este manual (folleto) antes de comenzar la instalación. Debido a la naturaleza y características de este producto, se recomienda que sea instalado por un Taller Autorizado Mitsubishi. Reservado el derecho a cambios en el diseño, fabricación, ilustraciones y textos.

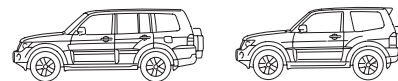

- FR** Lisez attentivement ces instructions avant de commencer l'installation. Du fait de la nature du produit il est fortement recommandé de s'adresser à un membre du réseau officiel Mitsubishi. Nous nous réservons le droit de modifier le design, la construction, les illustrations et les textes.
- HU** Kérem olvassák el az útmutatót alaposan mielőtt hozzákezdenek a beszereléshez. A terméket jellege miatt kizárólag Mitsubishi Márkaszerviz szerelheti be. A termékben dizájn, felépítés, illusztrációk és szöveg tekintetében a változtatás jogát fenntartjuk.
- NO** Les denne veiledningen nøye før montering starter. Dette er et avansert produkt der man under montering kan ha behov for spesielle måleinstrumenter. Det anbefales derfor at montering gjøres av et autorisert Mitsubishi verksted. Kopiering og bruk relatert til design, oppbygging, illustrasjon og tekst er reservert.
- RO** Cititi cu atentie aceste instructiuni inainte de a incepe instalarea. Datorita particularitatilor acestui produs se recomanda in mod expres instalarea acestuia intr-o Unitate Service Autorizata Mitsubishi. Modificarile legate de design, constructie, ilustratii si texte sunt rezervate.
- SE** Läs noggrant igenom alla instruktioner innan monteringen startas. På grund av produktens utformning och beskaffenhet rekommenderar vi starkt att monteringen görs utav en auktoriserad Mitsubishi-verkstad. Med reservation för förändringar av design, konstruktion, illustrationer och text.
- CZ** Čtete prosím následující pokyny pečlivě před začátkem instalace. Vzhledem k povaze výrobku vám doporučujeme provádět montáž u autorizovaného opravce Mitsubishi. Změny designu, konstrukce, vyobrazení a další jsou předem vyhrazeny.
- GR** Διαβάστε τις οδηγίες προσεκτικά πριν αρχίσετε την εγκατάσταση του εξαρτήματος στο όχημα. Οφειλόμενος στη φύση αυτού του προϊόντος, συνιστάται ιδιαίτερα να γίνει η εγκατάσταση του από ένα εξουσιοδοτημένο συνεργείο της Mitsubishi. Τροποποιήσεις στο σχέδιο, κατασκευή, απεικονίσεις ή και το κείμενο μπορούν να γίνουν δίχως κάποιο προηγούμενο προειδοποίηση.
- EE** Enne paigalduse alustamist tutvuge põhjalikult paigaldusjuhisega. Toode on mõeldud paigaldamiseks Mitsubishi volitatud esinduse töökoja poolt. Toote kujundus, konstruktsioon ja paigaldusjuhised on litsenseeritud.
- IS** Lesið leiðbeiningar vel áður en farið er í ísetningu. Vegna eiginleika þessarar vöru er stranglega farið fram á að ísetning sé gerð á viðurkenndu Mitsubishi þjónustuaðila. Hönnun þessara vöru eru þannig og bygging, útskýring og texti er réttur áskilinn.
- PL** Prosimy o uważne przeczytanie tej instrukcji przed rozpoczęciem montażu. Ze względu na charakter tego urządzenia zalecamy jego instalację w ASO Mitsubishi. Producent zastrzega sobie prawo do wprowadzenia zmian bez powiadomienia.
- MK** Прочитајте ги следните упатства внимателно пред да ја започнете постапката за инсталација. Поради природата на производот, се препорачува инсталацијата да се изврши во овластен сервисен центар на Mitsubishi Motors. Било каква модификација на системот во однос на дизајнот, конструкцијата, софтверот или дадените препораки, не е дозволен од производителот.
- TR** Montaja başlamadan önce bu talimatnameyi dikkatlice okuyunuz. Bu ürünün doğası gereği, montaj işleminin bir Mitsubishi yetkili servis noktasında yapılması önemle tavsiye edilir. Tasarım ile ilgili tadilatlar, konstrüksiyon, resimler ve dokümanın her hakkı saklıdır.
- DK** Læs denne vejledning grundigt inden montering påbegyndes. Grundet karakteren af dette produkt anbefales det at monteringen sker af en autoriseret Mitsubishi forhandler. Der tages forbehold for løbende ændringer i design, konstruktion, illustrationer og tekst.
- FI** Ennen asennuksen aloittamista lue nämä asennusohjeet huolellisesti. Asennus vaatii erityistä osaamista, joten on suositeltavaa teettää se valtuutetussa Mitsubishi-huoltokorjaamossa. Oikeudet muutoksiin tuotteessa, kuvissa ja tekstissä pidätetään.
- HR** Molimo pažljivo pročitajte ove upute prije početka instalacije!! Vežano za specifičnosti ovog proizvoda preporuča se ugradnja isključivo u ovlaštenom Mitsubishi servisu. Sva prava vezano za preinake u dizajnu, konstrukciji te ilustracijama i tekstu su pridržana.
- IT** Leggere attentamente le istruzioni prima di iniziare l'installazione. Per le caratteristiche proprie di questo prodotto è necessaria l'installazione da parte di un Centro Assistenza Autorizzato Mitsubishi. Resta salvo il diritto di eventuali modifiche relative a progetto, costruzione, illustrazioni e testo.
- NL** Lees deze instructies zorgvuldig door alvorens U tot installatie overgaat. Gezien de aard van dit produkt wordt het sterk aanbevolen de installatie door een erkend Mitsubishi Motors Service Centrum te laten uitvoeren. Veranderingen ten aanzien van ontwerp, constructie, afbeeldingen en tekst zijn voorbehouden.
- PT** Leia estas instruções com atenção antes de iniciar a montagem. Dada a natureza deste produto, é altamente recomendável que seja montado por um Ponto de Serviço Autorizado Mitsubishi. São reservadas quaisquer alterações relacionadas com o desenho, construção, ilustrações e texto.
- SI** Prosim Vas, da pred vgradnjo skrbno preberete ta navodila. Glede na naravo tega proizvoda, vam priporočamo, da je omenjena naprava vgrajena pri pooblaščenem serviserju Mitsubishi. Pridržujemo si pravico do spremembe oblike, konstrukcije, ilustracije ter teksta.
- LT** Prieš pradendant montavimą įdėmiai perskaitykite šias instrukcijas. Atsižvelgiant į šio produkto ypatybes, rekomenduojame jo montavimą atlikti Mitsubishi Autorizuotame Serviso Centre. Gamintojas pasilieka teisę keisti gaminio dizainą, konstrukciją, iliustracijas bei tekstą.
- LV** Pirms uzstādīšanas uzsākšanas, lūdzu, iepazīsties ar instrukciju rūpīgi! Ņemot vērā produkta īpašības tiek stingri rekomendēts uzstādīšanu veikt Mitsubishi autorizēta dīlera servisā. Informācija attiecināma uz konstrukciju, ilustrācijām un tekstu, kā arī dizains, var tikt mainīts laika gaitā, ja nepieciešams.
- RS** Molimo pažljivo pročitati uputstvo pre instalacije. Shodno specifičnosti proizvoda, preporučuje se da se instalacija seta izvrši u Mitsubishi ovlašćenom servisu. Izmene koje se odnose na dizajn, konstrukciju, ilustracije i tekst su zaštićene.

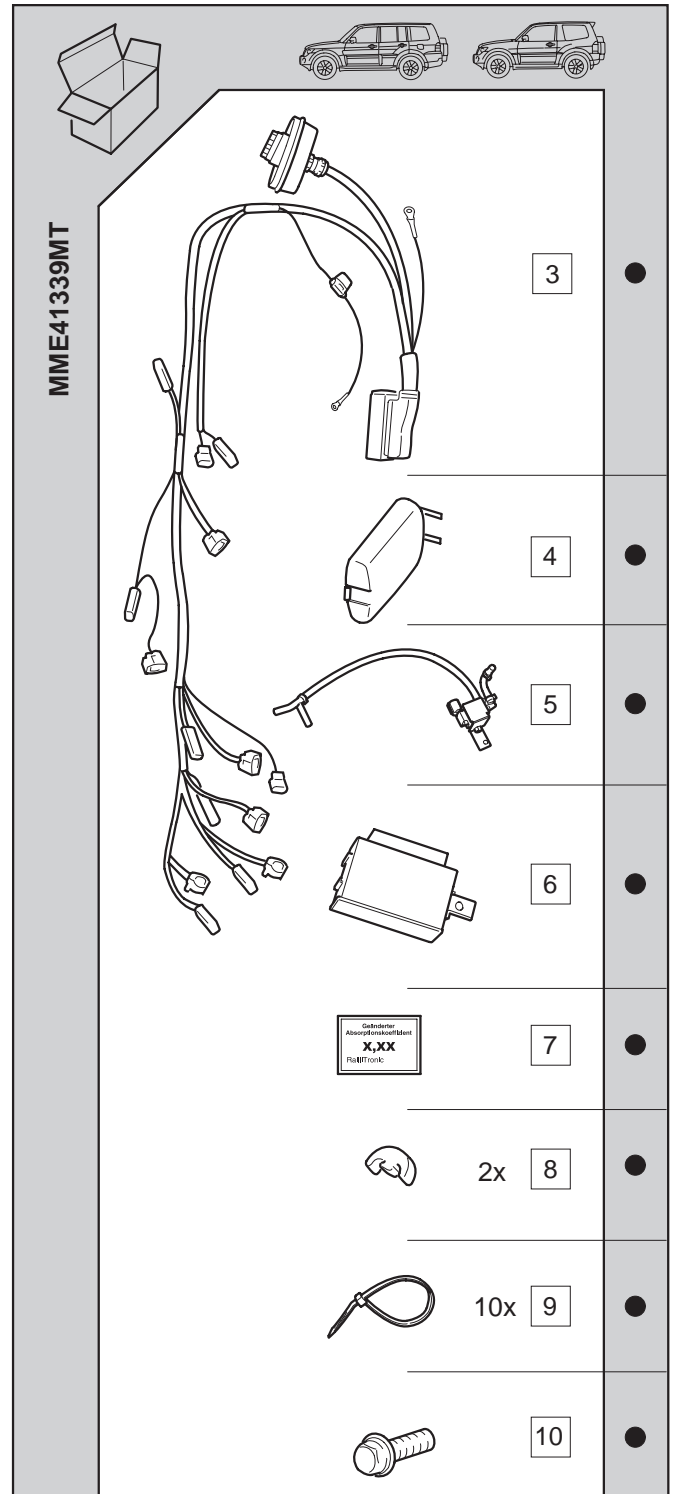
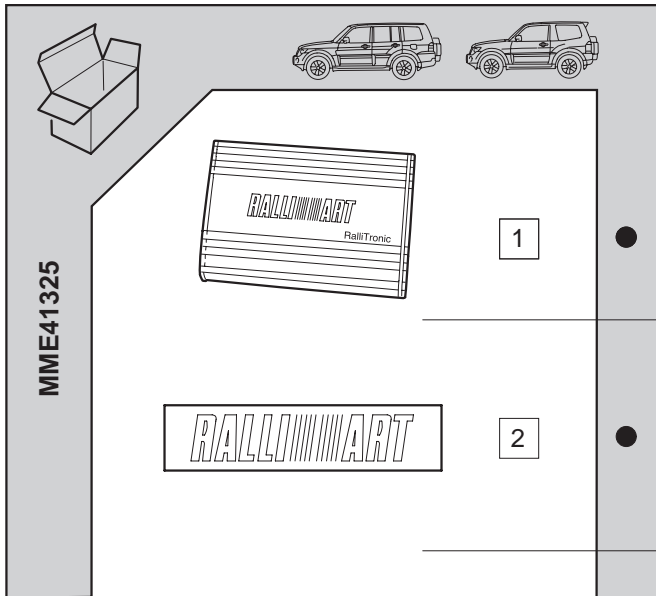
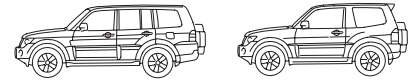

www.rallitronic.com
PAJERO 3.2L DI-D (MT)

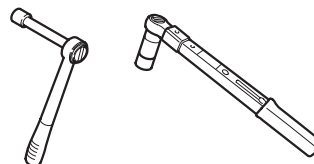
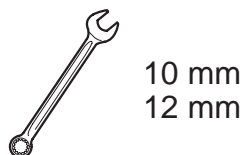
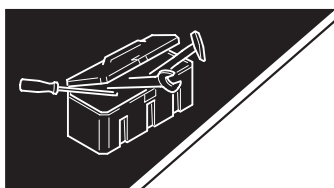
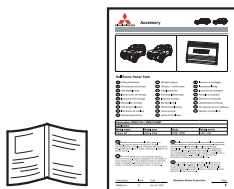

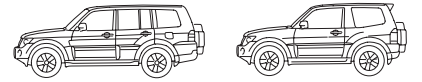

1

www.rallitronic.com
PAJERO 3.2L DI-D (MT)

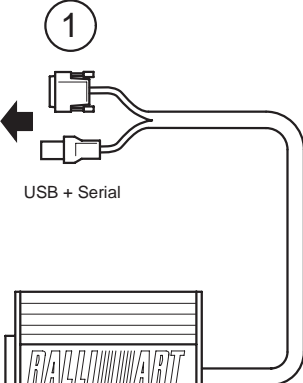
USB + Serial



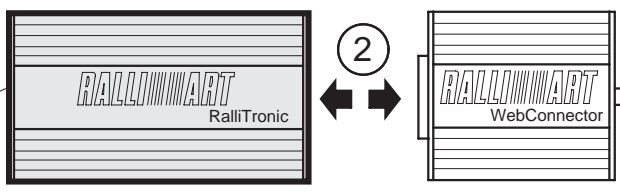



1

2

MME41316

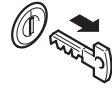
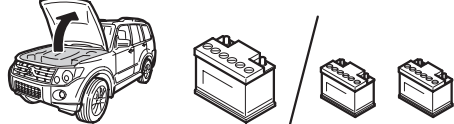
2

1

2



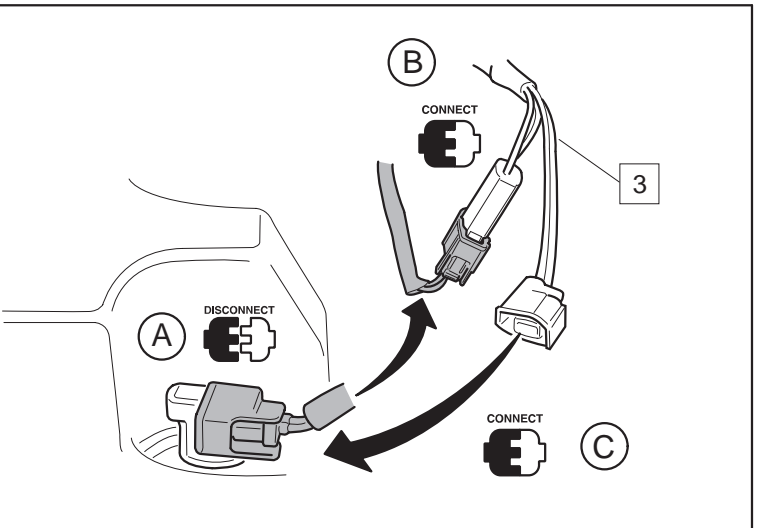
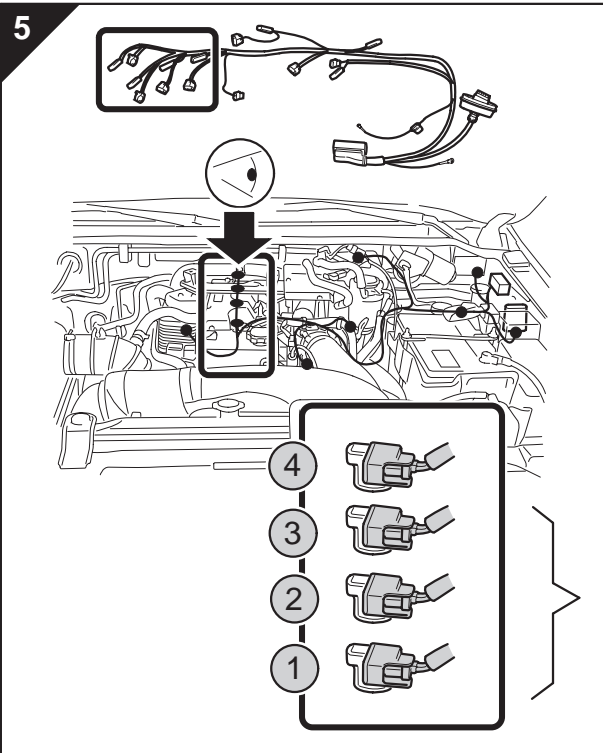
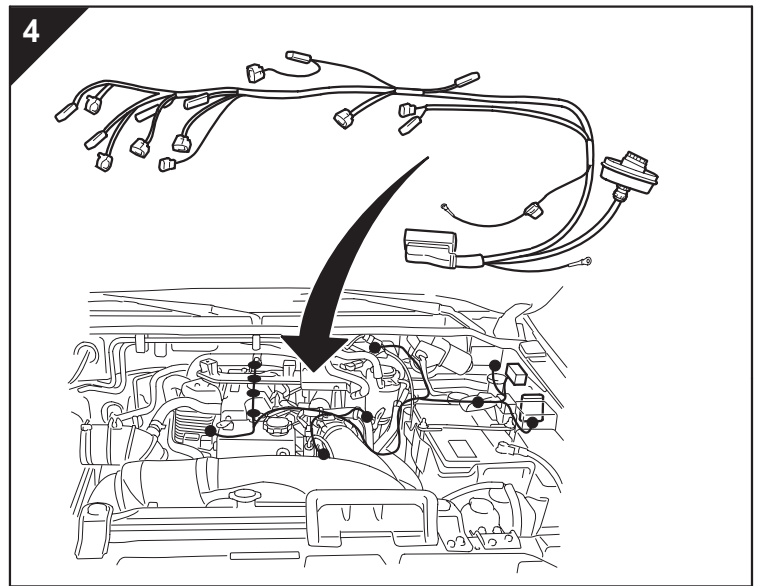
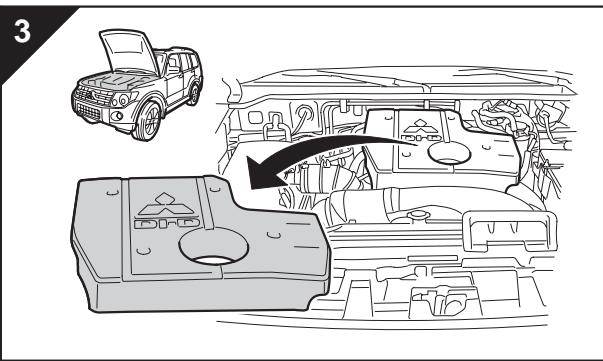

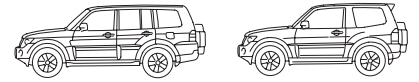
6

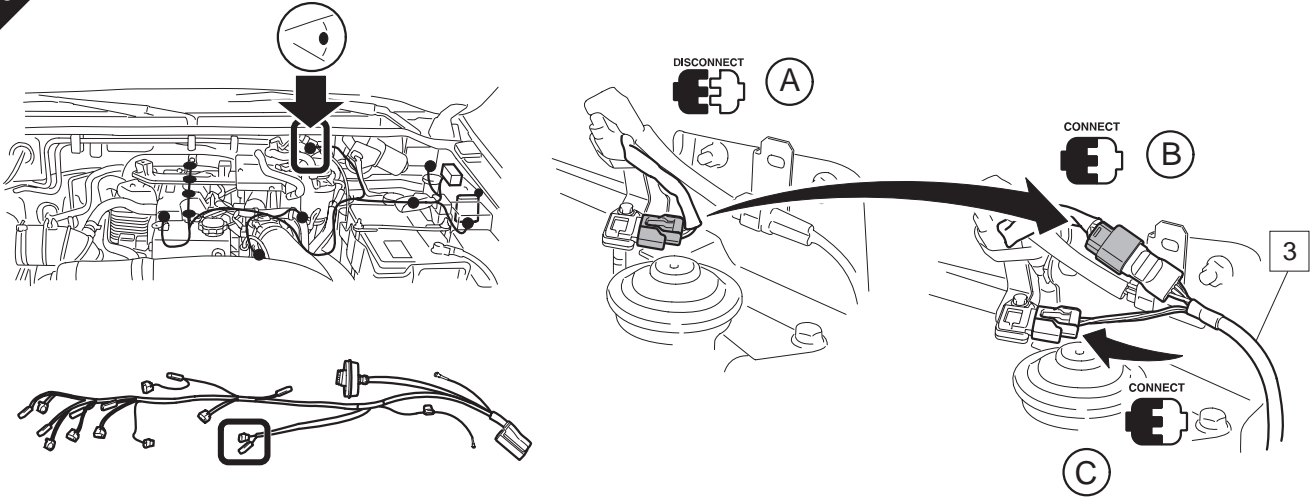

7

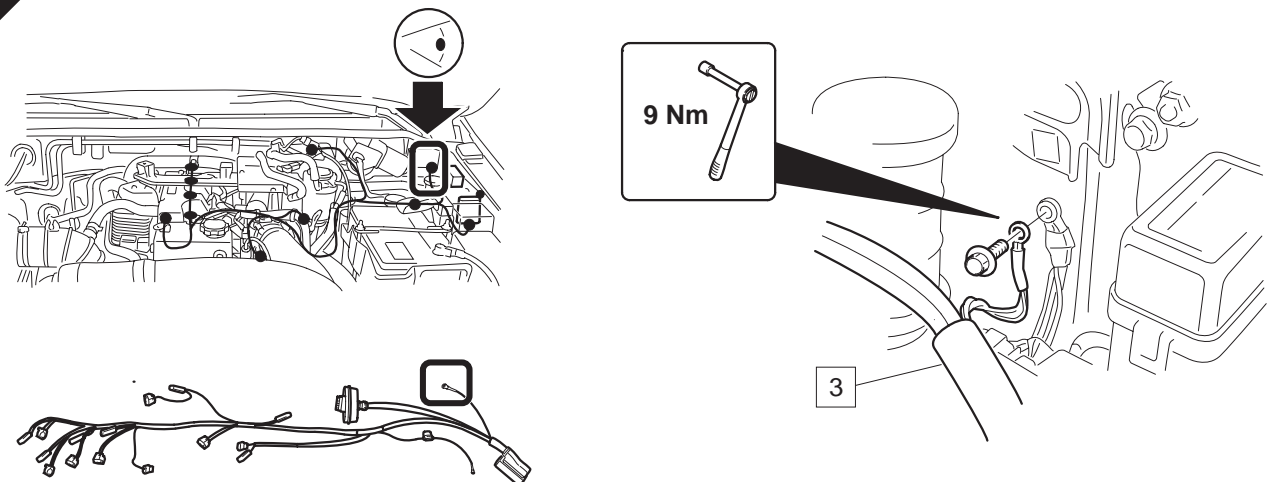

8

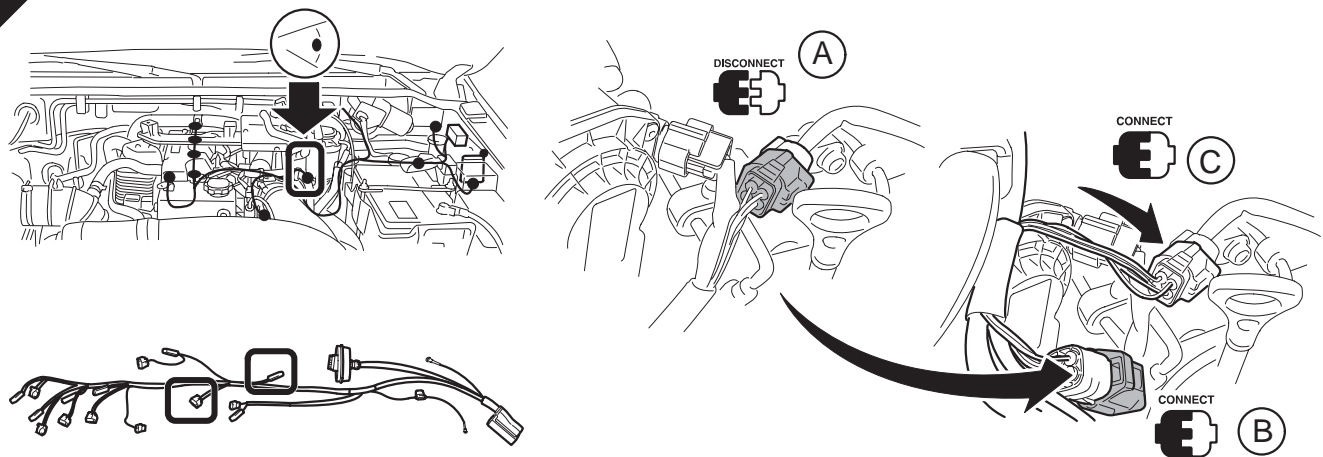

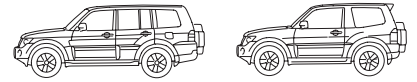

9

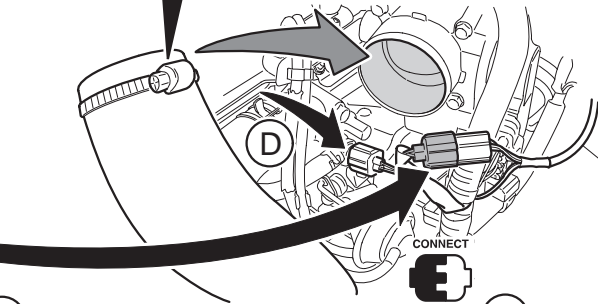
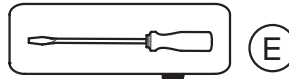
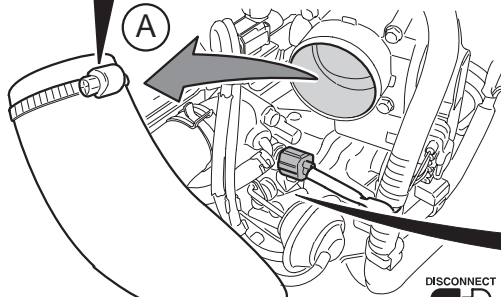
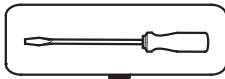
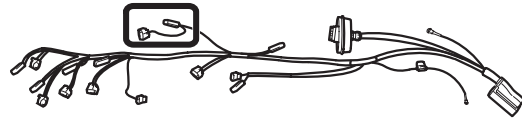
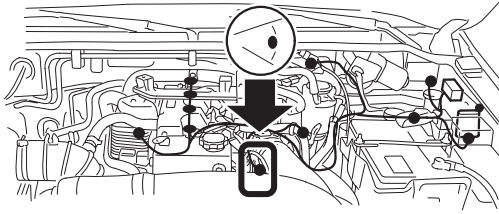

DISCONNECT



(B)

CONNECT



(C)

10

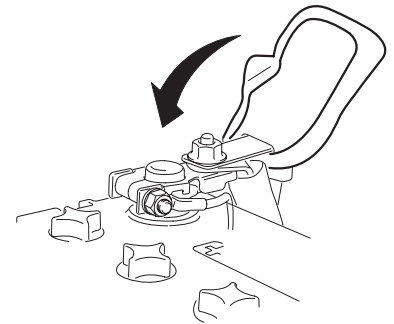
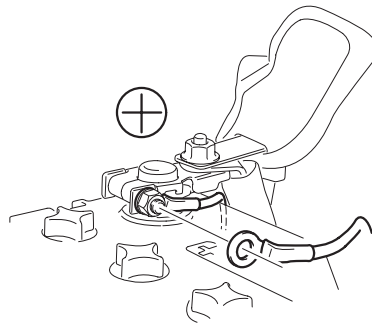
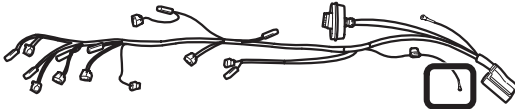
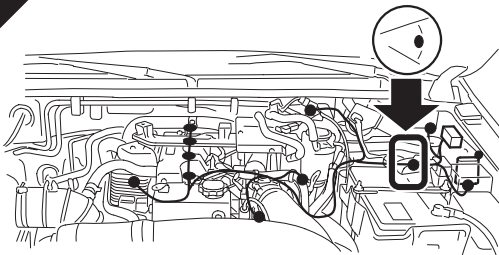

11

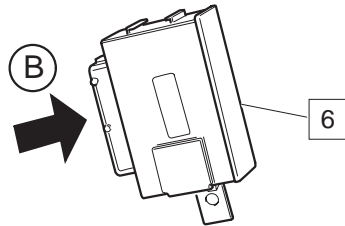
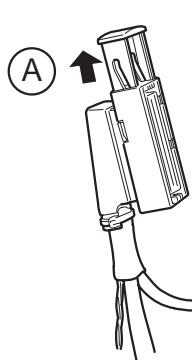
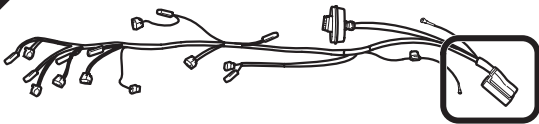

6

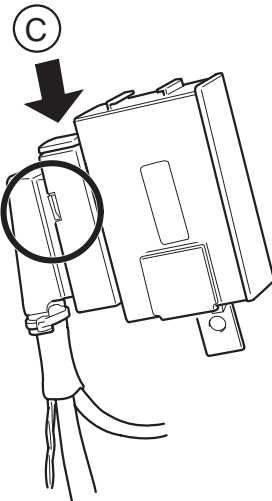
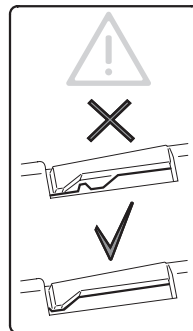

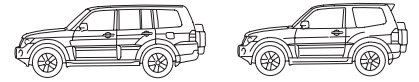

12

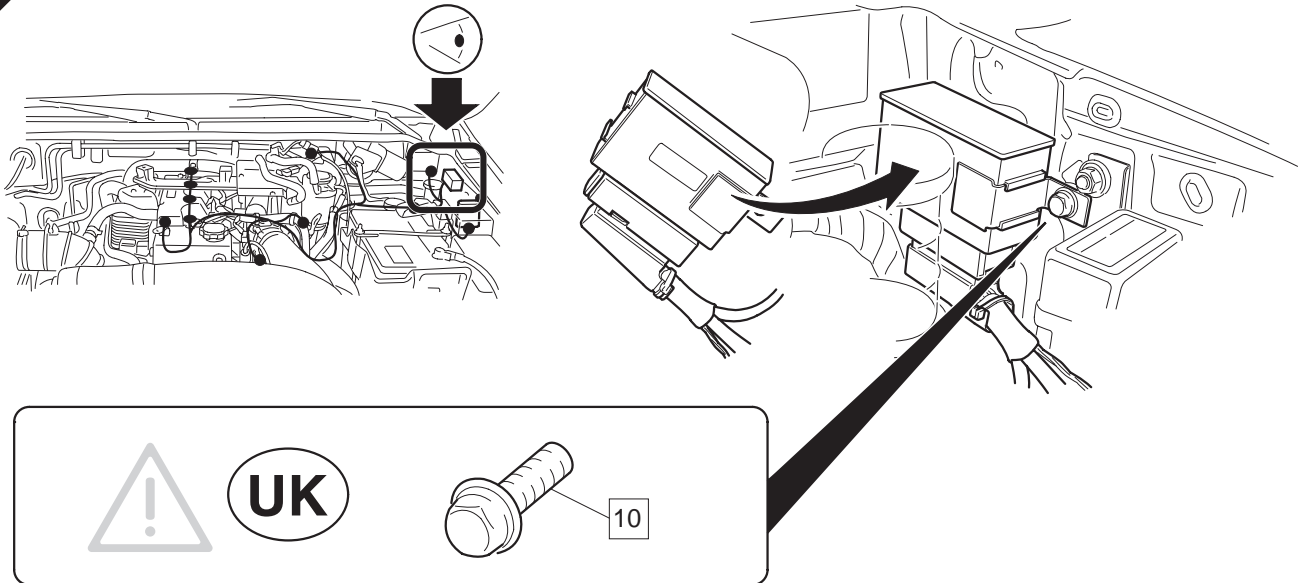

13

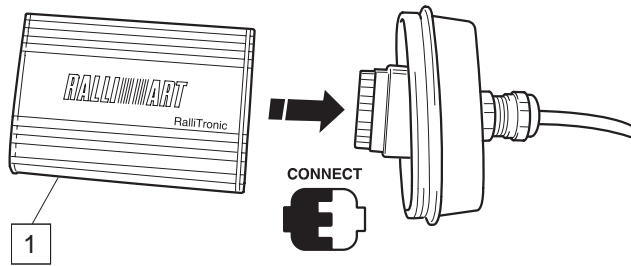

14

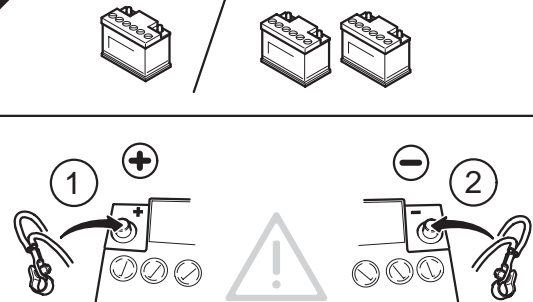

15

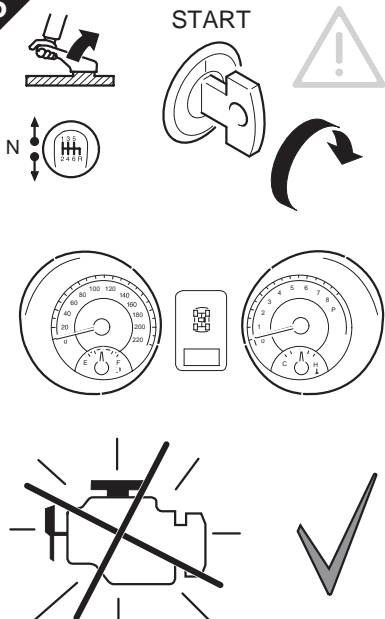

16

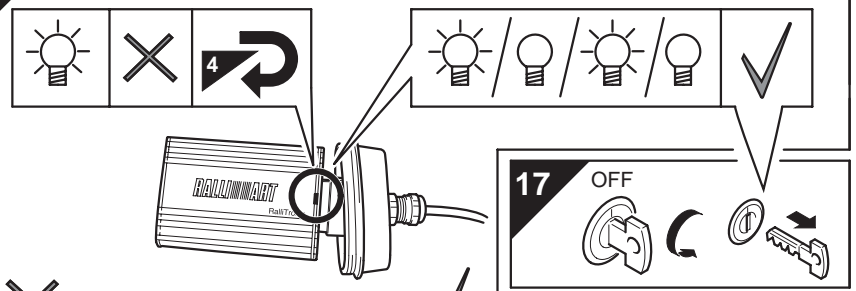

GB Red	CZ Červená	IT Rosso	GB Green	CZ Zelená	IT Verde
BG червено	GR Κόκκινο	NL Rood	BG Зелено	GR Πράσινο	NL Groen
DE Rot	EE Punane	PT Vermelho	DE Grün	EE Roheline	PT Verde
ES Rojo	IS Rautt	SI Rdeča	ES Verde	IS Grænt	SI Zelena
FR Rouge	PL Czerwony	LT Raudona	FR Vert	PL Zielony	LT Žalia
HU Piros	TR Kırmızı	LV Sarkans	HU Zöld	TR Yesil	LV Zaļš
NO Rød	DK Rød	MK Црвено	NO Grønn	DK Grøn	MK Зелена
RO Rosu	FI Punainen	RS Crveno	RO Verde	FI Vihreä	RS Zeleno
SE Röd	HR Crveno		SE Grön	HR Zeleno	

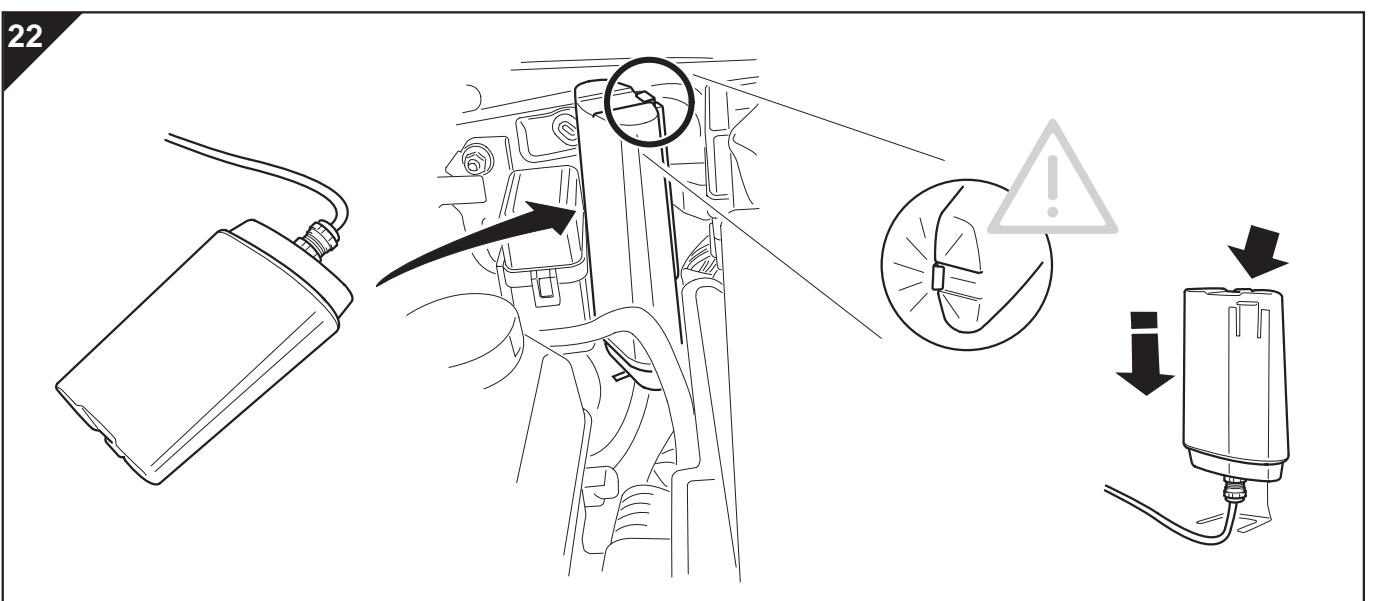
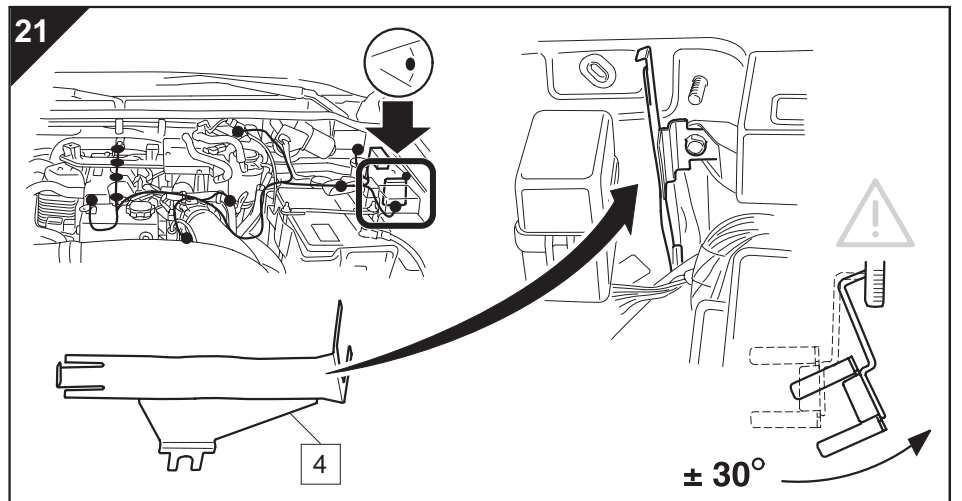
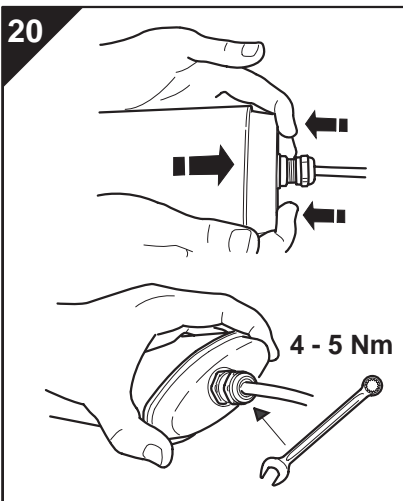
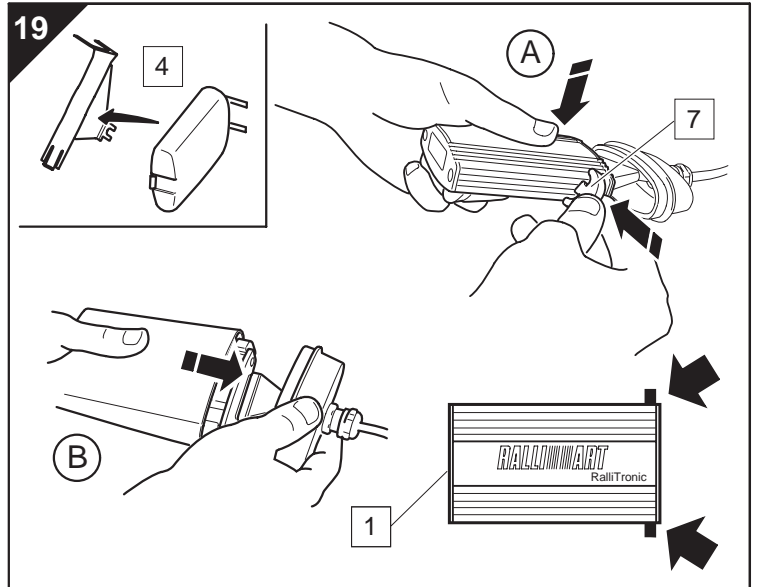
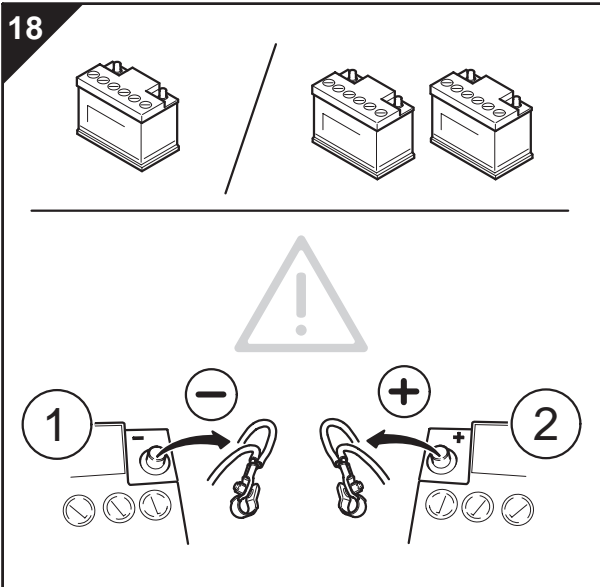
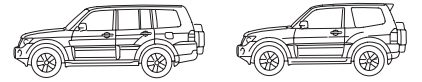

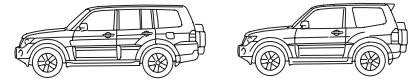

23

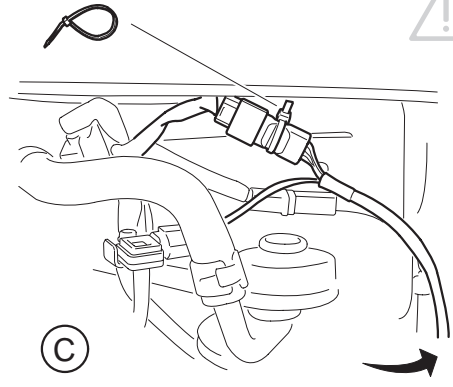
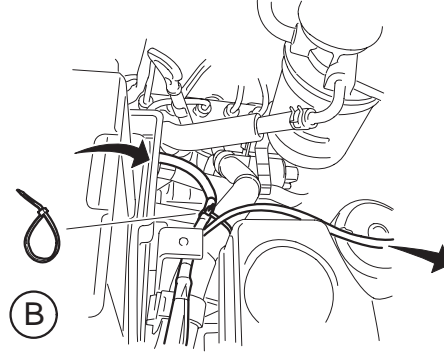
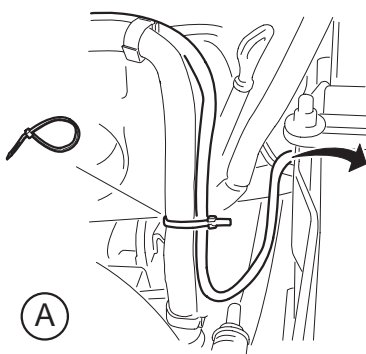
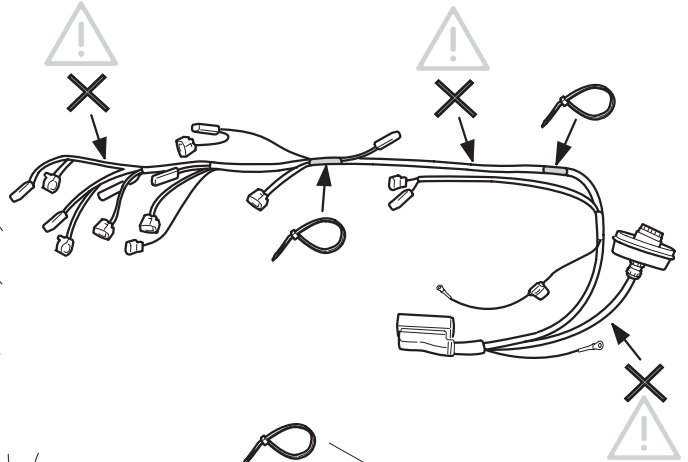
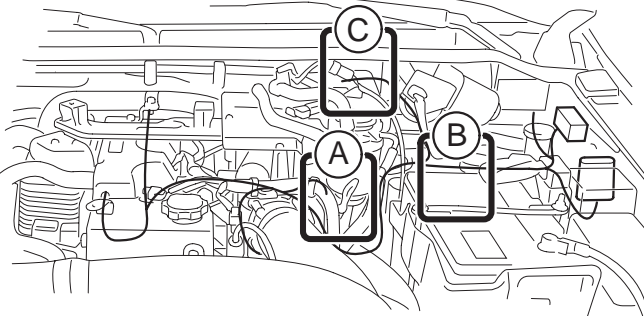

24

